

# Operation & Maintenance Manual

## For Northern® 4400, 4500, 4600, and 4800 Series Pumps

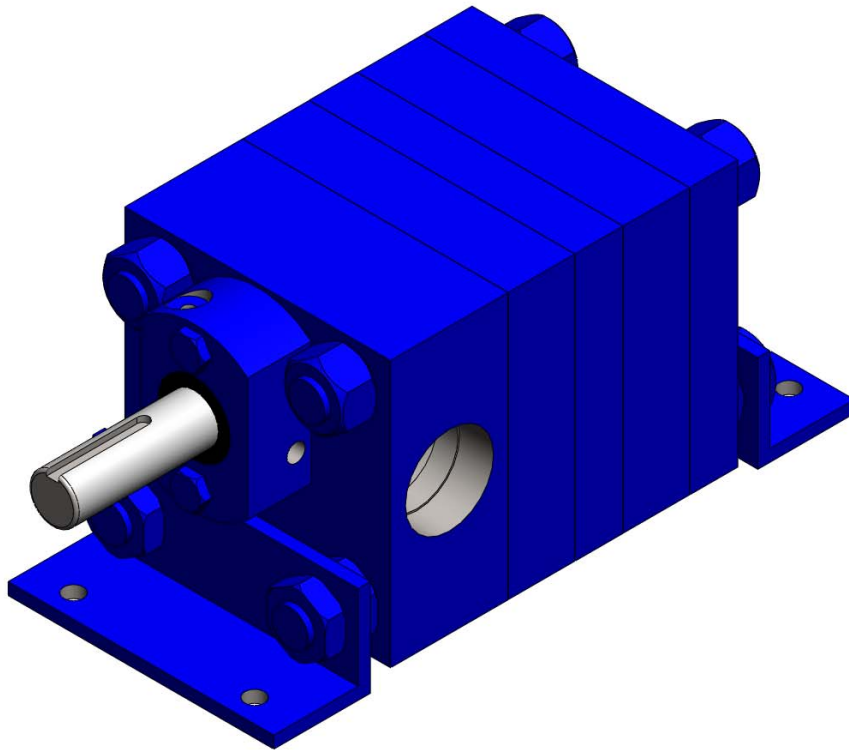

# Northern® Pump

A Division of McNally Industries, LLC

340 West Benson Avenue

Grantsburg, WI 54840

Toll Free: 1-800-366-1410

Phone: 715-463-5177

Fax: 715-463-5174

[www.northern-pump.com](http://www.northern-pump.com)



## Table of Contents

Introduction .....	3
Cautionary Statements.....	5
Pump Installation.....	5
Removal of Pump from Installation .....	6
Disassembly.....	6
Pump Disassembly Steps.....	7
Cleanup.....	11
Inspection .....	11
Assembly .....	12
Trouble Shooting.....	13
Lubrication and Preventative Maintenance.....	15
Appendix A: Exploded Drawing.....	A.I
Appendix B: Seal Replacement.....	B.I

## Introduction

The 4000 series gear pumps are a positive displacement, rotary pump with two gears of equal size. Fluid is drawn into the pump by the gear teeth as they come out of mesh and is carried to the discharge side of the pump by the rotating gears where it is forced from the pump by the meshing teeth. The inlet port of the pump is on the side where the gears are coming out of mesh; the discharge port is on the side of the pump where the gears are coming in to mesh.

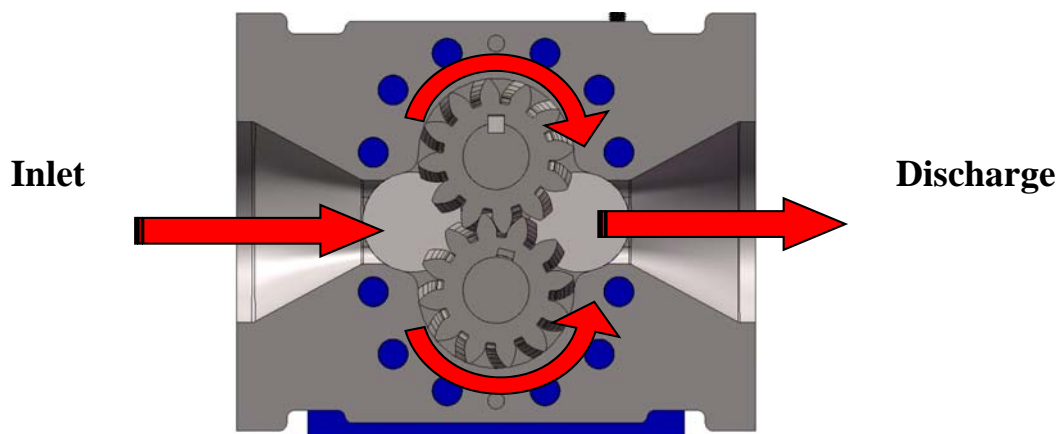

The pump has a constant discharge at constant rotational speed. Clearances of a few thousandths of an inch, at the edge and sides of each gear, vary with the size of the pump. The combination of the width of the gear and the speed of the pump determine the flow rate. There are many variations of the pump assembly possible depending on the application; such as roller bearings, bronze or carbon graphite sleeve bearings, an outboard bearing bracket and/or an internal relief valve.

Gear pumps, depending on the model, handle viscosities up to 1,500,000 cP, 200 gal/min, and discharge pressure up to 2,000 pounds per square inch (13,790 kPa). Studs fasten the components of the pump assembly together. The studs also serve as dowels for ensuring alignment of the plates. The mating surfaces of all plates are ground to a very smooth finish and are sealed by a thin coat of sealant or with O-rings.

Inlet and discharge connections are available to include but not limited to: bolt-on sanitary flanges, NPT ports, cast flanges, welded steel flanges of which are all typically located on the sides of the cylinder or seal adapter plates. In special circumstances can be added to the top of the seal adapter plate or through the rear of the pump. The shaft is typically sealed with a John Crane type mechanical seal or a variety of different types of packing depending on the duty requirements of the pump.

## Figure 1. General Configurations of 4000 Series Pumps

### Mechanical Seal

Cylinder with Flanged  
Connections

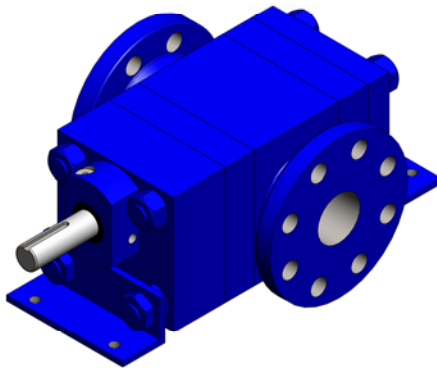

Seal Adapter Plate with NPT  
Connections

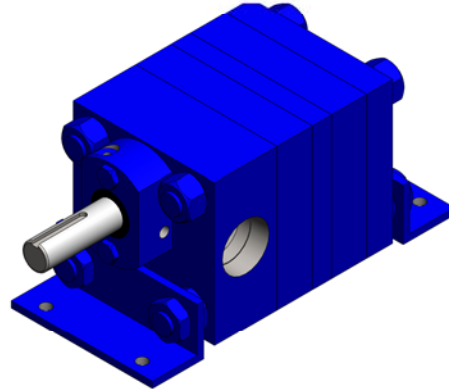

### Packing Set

Cylinder with Flanged  
Connections

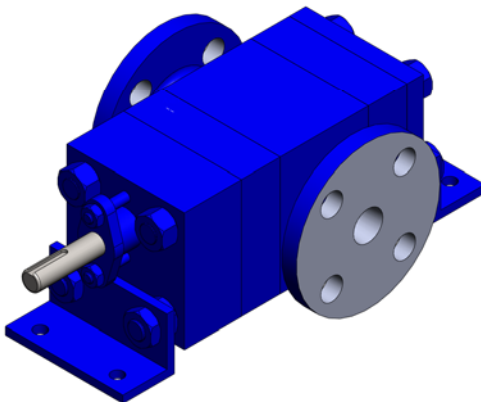

Seal Adapter Plate with  
NPT connections

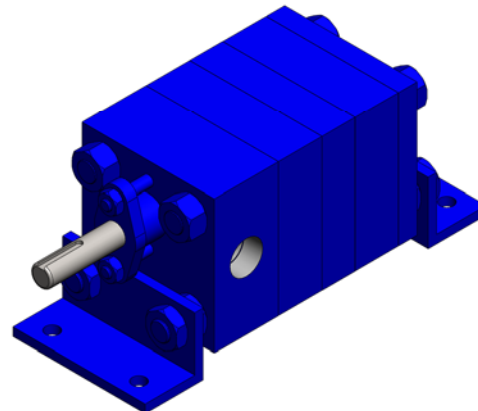

## Cautionary Statements

**Failure to heed these cautionary statements may result in personal injury and/or damage to equipment:**

1. Disable and lock-out the drive system before any work is done to install, maintain, or remove the pump.
2. Fully depressurize the entire system.
3. Close the valves closest to the pump in both the suction and discharge pipe.
4. Wear protective eyewear, and any other required face protection.
5. When handling corrosive, caustic, toxic, or hazardous liquids, wear protective clothing to prevent contact with skin.
6. Wear protective footwear such as safety shoes.
7. When handling liquids with toxic vapors, wear a properly rated breathing mask.
8. Work area must be properly ventilated.
9. Work area must be properly grounded.
10. Do not work alone.
11. Clean up any spilled liquid immediately.

## Pump Installation

Please refer to Appendix A for complete diagram of the gear pump.

1. 4000 series pumps are heavy. Use appropriate lifting and transportation methods and means (hoist, forklift, pallet jack, etc) when moving a pump.
2. Verify the drive mechanism is off and locked out.
3. Level and properly align pump.
4. Line pipes up naturally. Forcing pipes into place with flange bolts can draw pump out of alignment. Support pipes independently to eliminate strain on pump casing. Check alignment again and correct if necessary.
5. Test inlet pipe lines with pressure for leaks to ensure that they are completely airtight. The inlet piping must have a diameter equal to, or larger than, the pump inlet port.
6. Test rotation of the motor to ensure that the pump rotates in the direction indicated by arrow on pump casing.
7. Do not subject pumps to thermal shock by exposing a cold pump to a hot liquid supply or vice versa.

## Removal of Pump from Installation

Please refer to Appendix A for a complete diagram of a typical configuration gear pump.

1. Turn off and lock out the drive mechanism.
2. Fully depressurize both the suction and discharge lines to the pump.
3. Close the valve in the suction and discharge lines closest to the pump.
4. Place a pan or other liquid collecting device under the pump to collect the liquid that may drain from the pump or the suction and discharge lines when assembly is disconnected.
5. Once the pump is disconnected, rotate the pump so the discharge port is pointing down over the liquid collecting device and tilt pump forward allowing any fluid in the pump to drain. Repeat procedure for the suction port of the pump.
6. Remove the coupling hub and key from the drive shaft. Clean any residue from the drive shaft. Remove any burrs or upset metal from the surface of the drive shaft.

## Disassembly

The pump body is a series of plates held together with four studs. The faying surfaces of the plates are ground flat and sealed with sealant or with O-rings. Be prepared to use some force to take the pump apart.

Depending on the specific pump, please refer to Appendix B for proper disassembly and replacement of seal.

Before disassembly, mark the pump housing with a scribe line or permanent marker line along one edge and a diagonal from corner to corner. When the pump is reassembled, the parts will be easily arranged back to previous sequential order. Refrain from using a punch and hammer to dimple plates for identification. This causes deformation in the plates resulting in the possibility of the pump not sealing when reassembled.

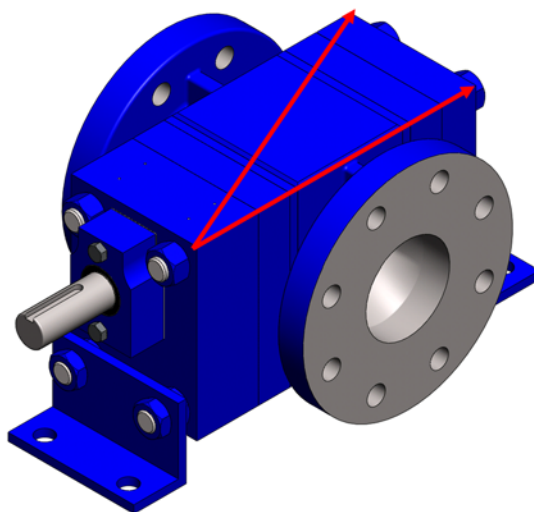

**Suggested marker  
or scribed lines  
across plates.**

## Clean-up

Clean all parts of the pump in accordance with specified cleaning procedures. Be prepared for exposure to specific chemical used in pump. Take all appropriate precautions to prevent damage to the parts of the pump during the cleaning process.

All pump parts accept a wide variety of acceptable cleaning methods or chemicals. All parts of the pump may be heated to 320°F (160 °C). Clean the flat surfaces of the pump body parts by rubbing them lightly on a fine sand paper (240-320 grit) stretched or laid on a flat ground surface. Move the part in either a circular or figure eight pattern to prevent fine scratches are not produced across the part. Wetting the sand paper with solvent will improve the ability of the sandpaper to clean the parts.

## Inspection

Visually inspect all parts for obvious problems- scratches on surfaces that mate with seals, cracks, upset metal that will affect how parts mate together, burrs, or other serious wear. Correct problem or replace part as necessary. Inspecting the following parts prior to assembly is recommended:

Inspect the shaft and bearing plates for excessive grooves or other signs of severe wear in bearing bores and gear wear surfaces:

- The bearing bores must be free of major scratches and major scoring.
- The lubrication groove must be clean.

Inspect the drive and driven shaft and gear for wear:

- No burrs or upset material is allowed on the surface of the drive shaft that mates with the coupling.
- Major nicks, scratches, grooves, or other defects could be a sign of imminent gear failure at the end surfaces of the gear.
- No major nicks, scratches, grooves, or other defects are allowed on the outside diameter of the gear.
- Visually inspect the gear teeth. The surfaces of the gear teeth must be smooth and free of obvious wear or damage.

Inspect the cylinder for wear:

- No nicks, burrs, or scratches are allowed on the ends of the cylinder.
- Visually inspect the gear bores for any sign that the gear has contacted the surface of the gear bore. No major nicks, scratches, grooves, or galling is allowed on the gear bore surface. If any of these conditions exist, replace affected parts as necessary.

Inspect the seal adapter plate:

- Visually inspect the matting surface for nicks, scratches, or burrs. No nicks, scratches, or burrs that will affect the mate-up of the parts at assembly or that will affect the ability of the O-ring to properly seal are allowed.

Inspect the bearing & seat housing:

- No scoring or other abnormal wear patterns are allowed on the bearing and bore. If necessary, the bearing may be pressed out of the Bearing housing and replaced by pressing in a new one.

Inspect the O-rings:

- No nicks, scratches, cuts, tears, or permanent deformation are allowed.
- The O-rings must be firm and pliable. Replacement of O-rings is recommended whenever the pump is disassembled.

## Assembly

### After Disassembly

Visually inspect all parts for scratches on surfaces that mate with seals, cracks, upset metal that will affect how parts mate together, burrs, or other serious wear. Correct problem or replace part as necessary. Complete disassembly procedures in reverse order.

Use a light coat of stable, pure, synthetic oil on the shafts, gear, and studs to facilitate assembly. Avoid touching the polished faying surfaces of the Mechanical Seal Head (16) and Seat (15). Torque the Heavy Hex Whole Nuts (4) and Jam Nuts (5) to the specified torque requirements listed in **Table 1**.

**Table 1.** Torque Requirements

Model Series	Torque/ft/lbs
4300	20
4400	40
4500	60
4600	120
4800	180
4900	180
5400	300

Drive shaft & gear should turn freely after completion of assembly.



## Trouble Shooting Guide

Standard for all 4000 series pumps

Issue	Solution
Key will not fit into keyway in drive shaft	Check for burrs and nicks in the keyway and on the key. Remove as required. Measure width of key and keyway, if an interference fit is found, reduce the width of the key.
Motor shaft turns but pump shaft does not	Verify that the coupling has been properly installed with the correct key in each hub. Verify that the set screws are properly tightened in each coupling hub.
Pump requires too much torque	Make sure that the viscosity of the liquid being pumped is not abnormally high. Check alignment of pump.
Pumped liquid has entrained air	Check for air leaks in suction line.
No liquid delivered	Verify rotation of pump to the motor. Clogged inlet. Air leaks on inlet side of pump or through shaft seal. Relief valve pressure setting too low or held off seat by foreign material.



<b>Issue</b>	<b>Solution</b>
Pump works for a while then quits	Leaky inlet piping. Inlet lift too high. Air or gas in the liquid.
Pump takes too much power	Pump speed or discharge pressure in excess of specifications. Liquid is thicker or more viscous than specified. Packing gland too tight, causing high friction in shaft seal. Pump not properly aligned.
Flow rate is too low	Make sure that the viscosity of the liquid being pumped is not abnormally low. Make sure that the discharge pressure is not abnormally high. Make sure that there are no air leaks in the suction line. Verify that the rotational speed is correct. Disassemble pump and verify that the internal clearances are within specification.
Pump makes too much noise	Air or gas in fluid being pumped. Air leaking into inlet pipe or through shaft seal. Inlet velocity too high due to using inlet piping smaller than pump inlet opening. Inlet pipe not submerged deeply enough or too close to return line causing pump to intake liquid/air mixture. Relief valve chattering. Wrong direction of rotation. Pump not properly aligned.

## Lubrication and Preventative Maintenance

The pump is fully lubricated by the pumped liquid. Dry running must be avoided, as it will cause internal damage to the pump.

It is recommended that a very small amount of a liquid compatible with the liquid to be pumped be put into the pump at startup. This will lubricate the pump during the startup period.

Service the grease seal housing bearing on pumps with general purpose bearing grease every six months or every 500 hours of operation, whichever occurs first.

**Grease  
Fitting**

